

Installation, Operation and Service Manual

IMPORTANT: READ CAREFULLY BEFORE INSTALLING OR OPERATING LIFT



Toll Free 877-515-8297



CBD-30-005

CBD-30-010

Model Number _____

Serial # _____

Date placed in service _____

Part orders are subject to a \$50 minimum charge.

Manual updated October 2014

This manual was current at the time of printing. To obtain the latest, most updated version, please contact LiftCOA Service Department or go to our website: www.LiftCOA.com -- you will find a complete list of current owner's manuals to print.

CONTENTS

INTRODUCTION	4
Responsibility of Owners and Users.....	5
Safety Alert Symbols and Signal Words	6
Safe Servicing of the Lift.....	7
SAFETY	8
INSTALLATION INSTRUCTIONS	8
Preparation	8
Positioning the Lift	9
Hydraulic Connections	9
Electrical Connections.....	9
Testing	9
Completing Installation	10
Preparing to Charge a Battery.....	11
Battery Charger Connections & Precautions.....	11
OPERATING INSTRUCTIONS	12
Operating Procedure	12
MAINTENANCE	15
Hazards	15
Routine Periodic Maintenance	15
Units with Air Motors.....	16
TROUBLESHOOTING	16
Troubleshooting Check List	16
Will Not Raise	16
Fails to Hold a Load.....	17
Fails to Lower	17
Repacking Cylinders.....	17
Replacing Leg Rollers	19
RMA (Return Materials Authorization) PROCEDURES.....	26
WARRANTY	Back Page

List of Figures & Tables

Figure 1	Safe Servicing of Lift	7
Figure 2	Mount the Lift Securely	8
Figure 3	Center the Load	12
Figure 4	Secure the Load	12
Figure 5	Pinch Points - CBD	13
Figure 6	Pinch Points - CBD	13
Figure 7	Labels and Precautionary Markings	14
Figure 8	H-Style Cylinder	19
Figure 9	Parts Identification, CBD	20
Figure 10	Hydraulic Diagram - Unit Powered by Electric Motor	21
Figure 11	Hydraulic Pump and Down Valve	21
Figure 12	Hydraulic Diagram - Unit with Air Motor	22
Figure 13	Hydraulic Connections	22
Figure 14	Electrical Connections, diagram for Single-Phase AC	23
Figure 15	Electrical Connections, diagram for Three-Phase AC	24
Table 1	Hydraulic Oil Specifications	25

INTRODUCTION

The CBD Lift series includes Compact models with maximum capacity and vertical travel that can be provided in a small footprint with minimal lowered height. All CBD Lift models can be supplied with a large variety of table top sizes, optional accessories, power source and controls to suit the customer's needs. The minimum platform design is primarily for applications and installations in confined spaces. Overall, the CBD lift series has been developed and tested to ensure it meets the highest possible performance standards.

This manual contains information to acquaint you with the safe and proper installation, use, and maintenance of the CBD Lift. You should ensure that this manual is available to personnel working with the CBD Lift and require its use by these personnel. CBD Lift tables are designed for lifting and vertical positioning of equipment and materials in a wide variety of industrial settings. The instructions set forth in this manual are not necessarily all-inclusive, as LiftCOA cannot anticipate all conceivable or unique situations. In the interest of safety, please read this entire manual carefully, and be familiar with its contents before you install, use, or service the CBD Lift table. If you have any questions about any instructions in this manual, please contact your dealer or Lift Company of America. LiftCOA's product warranty is shown on the back cover of this manual.

This instruction manual is not intended to be or to create any other warranty, expressed or implied, including any implied warranty of merchantability or fitness for a particular purpose, all of which are hereby expressly excluded. As set forth more specifically in the product warranty. LiftCOA's obligation under that warranty is limited to the repair or replacement of defective components, which shall be the buyer's sole remedy. LiftCOA shall not be liable for any loss, injury, or damage to persons or property, nor for any direct, indirect, or consequential damage of any kind resulting from the lift table.

Responsibility of Owners and Users

Inspection and Maintenance

The device shall be inspected and maintained in proper working order in accordance with LiftCOA's owner's manual.

Removal from Service

Any device not in safe operating condition such as, but not limited to, excessive leakage, missing rollers, pins, or fasteners, any bent or cracked structural members, cut or frayed electric or hydraulic lines, damaged or malfunctioning controls or safety devices, etc. shall be removed from service until it is repaired to the original manufacturer's standards.

Repairs

All repairs shall be made by qualified personnel in conformance with LiftCOA's instructions.

Before Operation

Before using the device, the operator shall have:

- Read and/or had explained, and understood, the manufacturer's operating instructions and safety rules.
- Inspected the device for proper operation and condition. Any suspect item shall be carefully examined and a determination made by a qualified person as to whether it constitutes a hazard. All items not in conformance with LiftCOA's specification shall be corrected before further use of the equipment.

During Operation

The device shall only be used in accordance with this owner's manual.

- Do not overload.
- Ensure that all safety devices are operational and in place.

Modifications or Alterations

Modifications or alterations to any LiftCOA industrial positioning equipment shall be made only with written permission from LiftCOA.

SAFETY ALERT SYMBOLS AND SIGNAL WORDS

The safety of all persons operating, maintaining, repairing, or in the vicinity of this equipment is of paramount concern. This is a powerful machine with moving parts, and is capable of causing personal injury if proper precautions are not taken. Therefore, throughout this manual, certain hazards have been identified which may occur in the use of the machine, and there are appropriate instructions or precautions which should be taken to avoid these hazards. In some cases, there are consequences which may occur if instructions or precautions are not followed. Below are the symbols and signal words along with their definitions referenced from ANSI Z535.4 - Product Safety Signs and Labels.

Safety Alert Symbols

These are the safety alert symbols. They are used to alert you to potential physical injury hazards. Obey all safety messages that follow this symbol to avoid possible injury or death.



For use with **DANGER** signal word
(Red Background)



For use with **WARNING** signal word
(Orange Background)



For use with **CAUTION** signal word
(Yellow Background)

Signal Words

The meaning of different signal words as defined by ANSI Standard Z535.4 indicates the relative seriousness of the hazardous situation.



(Red Background)

DANGER indicates a hazardous situation which, if not avoided, will result in death or serious injury.



(Orange Background)

WARNING indicates a hazardous situation which, if not avoided, could result in death or serious injury.



(Yellow Background)

CAUTION, used with the safety alert symbol, indicates a hazardous situation which, if not avoided, could result in minor or moderate injury.



(Blue Background)

NOTICE is used to address practices not related to personal injury.



(Green Background)

SAFETY INSTRUCTIONS (or equivalent) signs indicate safety-related instructions or procedures.

SAFE SERVICING OF THE LIFT

This is the only safe way to work under a lift table. In this manual, we will refer you to this procedure many times. **In the interest of safety, please follow all of these steps whenever you work under the lift table:**

1. **Remove the payload** from the table top.
2. **Raise the lift table** to the full up position. Do not let the table stop part way up.
3. **Move both maintenance devices** into position as shown in Fig. 1. Lower the table just a bit so the movable legs are resting against the maintenance devices. This will release the pressure in the hydraulic system. If you do not do this, pressure may remain in the hydraulic system. If this pressure is released suddenly, you may be hurt, or the lift may be damaged. Once in position the maintenance devices will keep the legs from moving, and prevent the lift from dropping suddenly.

WARNING

Be sure to use both the left and right maintenance devices. Both the left and right maintenance devices supplied with your machine must be used to support the table safely.

4. **Complete the work** under the lift table, then reverse the process to get the lift ready for operation.
5. **Repeat this procedure** everytime you must work under the lift table. Do this even if you will only be under the table for a moment!

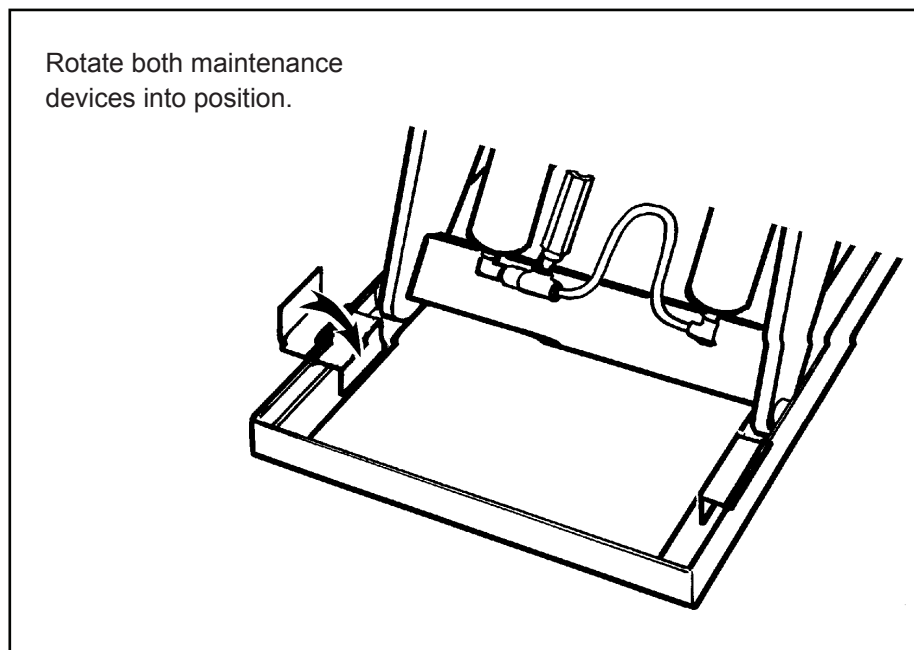

Figure 1 – Safe Servicing of Lift

SAFETY

The safety of all persons operating, maintaining, repairing, or in the vicinity of the CBD Lift is of paramount concern to LiftCOA. The CBD Lift is a powerful machine with moving parts, and is **capable of causing personal injury if proper precautions are not taken**.

Therefore, throughout this manual, LiftCOA has identified certain hazards which may occur in the use of the CBD Lift, and provided appropriate **instructions** or **precautions** which should be taken to avoid these hazards. In some cases, LiftCOA has also pointed out the **consequences** that may occur if LiftCOA's instructions or precautions are not followed. LiftCOA uses the following system of identifying the severity of the hazards associated with its products:

SIGNAL WORD

The word or words that designate a degree or level of hazard seriousness. The signal words for product safety signs are **“DANGER, WARNING and CAUTION”**.



Immediate hazard which will result in severe personal injury or death.



Hazardous or unsafe practice which could result in severe personal injury or death



Hazardous or unsafe practice which could result in minor personal injury or property damage. Please read and follow the instructions in this manual, including all safety instructions and precautions, carefully and completely.

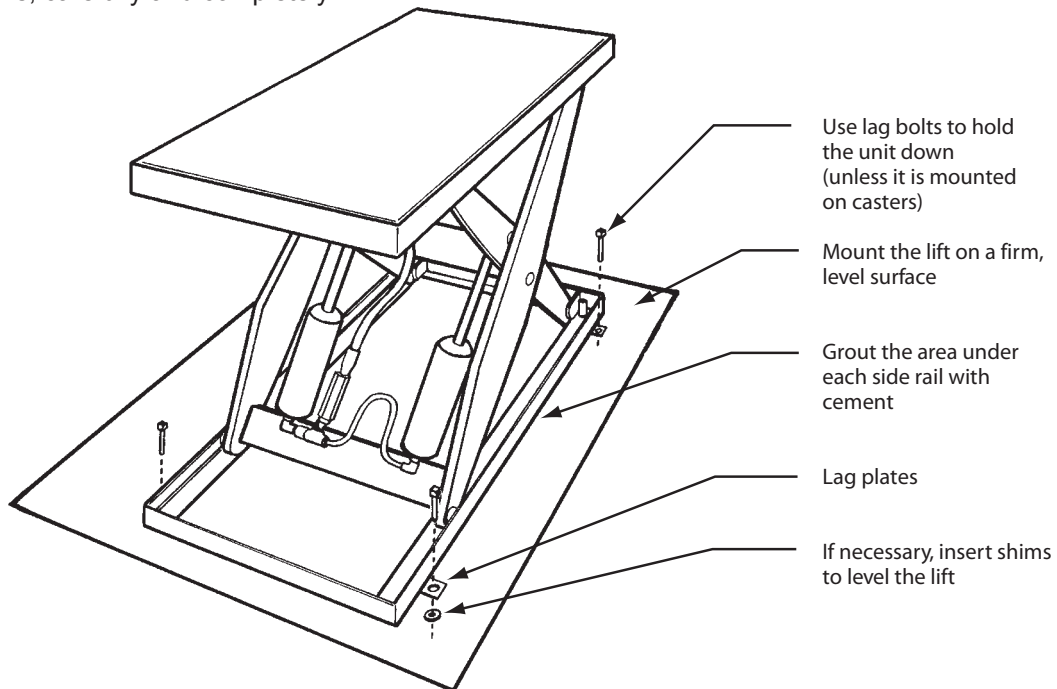

Figure 2 – Mount the Lift Securely (CBD)

INSTALLATION INSTRUCTIONS

CBD Lift

Preparation

Before you start to install the lift, check for local codes and ordinances which may apply. It is your responsibility to obtain any necessary permits. Read all of these

installation instructions carefully. Be sure to read and understand all of the warnings! If the power unit will be mounted away from the lift (“external power unit”), check the mounting arrangement for the power unit. The power unit should be sheltered from the weather. It should be mounted within 20 feet of the lift to minimize the pressure drop in the hydraulic system. Be sure the hydraulic lines have been installed properly.



Protect the power unit from rain or moisture. If the electrical parts in the power unit get

wet, workers may be hurt by electrical shock. The electrical parts may fail if they are wet.

⚠️WARNING

The electric motor in the lift can create sparks. Do not install the power unit in an area where flammable gases may be present.

If the power unit is mounted within the lift (“internal power unit”), you will need these tools:

- A crane or lift truck that can lift the unit safely.
- Shims and lag bolts.
- A drill and bit to drill the holes for the lag bolts.
- A power supply with the specified voltage, including fuses or circuit breakers as specified in Figures 14 and 15.

If the power unit will be mounted away from the lift (“external power unit”), you will also need:

- A compressed air source for clearing the hydraulic lines.
- Extra hydraulic oil for flushing the underground lines and refilling the tank. See Table 1 for the oil specifications.

Positioning the Lift

Remove the shipping material and unskid the lift. On the front of this manual, write down the model number, serial number, and date the lift is placed in service. You can find the model number and serial number on the name plate as shown in Figure 7. You cannot see the name plate without lifting the table top. Use an overhead crane or fork truck to do this. Lift the hinged end of the table top. Move the lift into position, supporting the base of the lift. Install the lift as shown in Figure 2.

⚠️CAUTION

Do not hang the lift from the table top. This can damage the lift.

⚠️WARNING

If the lift is mounted on an unstable surface, it may tip over when it is in use. You may be hurt, and the lift and load may be damaged.

Hydraulic Connections

Install the power unit. Install the hydraulic line between the power unit and the lift. Blow out the hydraulic line with compressed air before connecting it to the power unit. Replace the solid plug on the hydraulic fluid tank with the vented plug supplied, then attach the vent line from the cylinder(s) to the vented plug.

⚠️WARNING

Be sure that the hydraulic line will not be pinched by the lift as it raises or lowers. If you allow the line to be pinched, the lift may not work properly. A hose may break, the lift table may drop suddenly, and someone may be hurt.

NOTICE

It is very important to keep the hydraulic oil free of dirt, dust, metal chips, water, and other contamination. Most of the problems with hydraulic systems are caused by contamination in the oil. Be sure to flush all hydraulic lines before connecting remote power units.

⚠️CAUTION

If you do not install the vented plug in the tank, the pump may be damaged.

Electrical Connections

⚠️DANGER

The lift may use a power supply of up to 115 Volts AC. This voltage can kill you. Do not work with the electrical parts unless you are a qualified electrician.

Make temporary electrical connections to the lift, as shown in Figure 14 or 15. This temporary set-up will allow you to raise the lift.

⚠️WARNING

A 20 amp breaker is required.

⚠️CAUTION

If you have a unit designed for three-phase AC and you connect the power so the motor runs backwards, the lift will not operate, and you may damage the pump. Do not operate the lift for more than 2 or 3 seconds if you think the motor might be turning backwards. NOTE: Make sure the maintenance devices are not in the roller path.

Raise the lift and insert the maintenance devices, as shown in Figure 1. Make the permanent electrical connections as shown in Figure 14 or 15. Check the level of the hydraulic fluid. On most models, when the lift is fully elevated, the oil should be about 3/4 inch above the bottom of the tank. Use a dipstick to check the oil level, and add oil as necessary.

Testing (applies to all lifts)

Clear the area around the lift. Remove any loose wires, lumber, or other materials that might get in the way of the lift as it raises or lowers. Make sure

the maintenance devices are not in the roller path. Remove the maintenance devices and warn others to stay away from the lift. Operate the lift through its full range of travel. The lift should rise smoothly with a quiet humming sound, and lower smoothly and quietly. Raise and lower the lift a few times to check the clearances around the lift table.

⚠️ WARNING

As the lift table moves up and down, “pinch points” are created at the places shown in Figure 5 or Figure 6. If you are standing too close to the lift when it is moving, your arm or leg may be caught in the moving parts, and you may be hurt. Stay away from the pinch points when the lift is moving.

Completing Installation

Once you are sure the lift is positioned correctly, mark the locations of the lag holes in the base frame, and drill the holes. If necessary, insert metal shims to level the base of the lift. Insert and tighten the lag bolts to secure the lift. Grout under the base rails to prevent vibration and distortion of the base frame, as shown in Figure 2. If the lift is lowering too quickly or too slowly, you can change the “down speed” by adjusting the flow control. (optional feature)

⚠️ WARNING

When adjusting the flow control, always raise the lift table and insert the maintenance devices, as shown in Figure 1. Do not try to adjust the flow control while pressing the “down” button. If you try this, the lift table may drop suddenly, and you may be hurt.

It is important that you follow these steps when adjusting the flow control:

- Raise the lift table and insert the maintenance devices, as shown in Figure 1.
- If you want the lift to lower more slowly, turn the control clockwise up to 1/4 turn at a time. If you want the lift to lower more quickly, turn the control counterclockwise up to 1/4 turn. Do not move the control more than 1/4 turn at a time.
- Remove the maintenance devices, and check the descent speed.
- Every time you want to change the adjustment again, raise the table again and insert the maintenance devices as shown in Figure 1.

Test the lift with the rated load. If the lift does not rise, and you hear a loud squealing noise, the pressure relief valve is operating. Contact LiftCOA for instructions.

⚠️ WARNING

Do not continue to use the lift if this happens – the pump will overheat very quickly, and may be permanently damaged. Do not try to adjust the relief valve. If you change the setting on the relief valve, you may overwork the lift. This can cause the lift to fail suddenly, and you may be hurt.

PRECAUTIONS FOR GROUNDING AN AC POWER CORD CONNECTION

Charger should be grounded to reduce the risk of electric shock. Charger is equipped with an electrical cord having an equipment-grounding conductor and grounding plug. The plug must be plugged into an outlet that is properly installed and grounded in accordance with all local codes and ordinances.

⚠️ DANGER

Never alter the AC cord or plug provided. If it will not fit outlet, have proper outlet installed by a qualified electrician. Improper connection can result in a risk of electric shock.

DC POWER UNIT WITH CHARGER

This power unit comes equipped with a 12 Volt DC motor, gear pump, reservoir and 12 Volt DC battery with charger. When charging the battery it is important to remember that the lift should not be operated. Also the lift should be elevated resting on the maintenance devices for ventilation purposes. The battery charging procedure will take an estimated 5.5 hours to complete. The charger is equipped with an automatic shut off switch which enables the unit to be charged whenever it is not in service.

LOCATING THE CHARGER

Locate the charger as far away from the battery as the cables permit above floor level. Do not operate the charger in a closed area or restrict ventilation in any way

Preparing to Charge a Battery

1. Be sure area around lift and the battery is well ventilated while battery is being charged.
2. The battery terminals, connections and wiring including the plug in the battery box and charger connections should be clean and free of corrosion. When cleaning any of these components wear a face shield or suitable protective eyewear.
3. For a sealed battery (a battery without cell caps) carefully follow the manufacturer's recharging instructions which are provided with the battery. If you do not have a copy of these instructions or the instructions for the battery charger, they are available free of charge by calling LiftCOA at 812-222-2005.
4. Read, understand and follow all battery and battery charger manufacturer's specific precautions while working with and/or charging batteries.

PRECAUTIONS FOR GROUNDING AND AC POWER CORD CONNECTIONS

Charger should be grounded to reduce the risk of electric shock. Charger is equipped with an electrical cord having an equipment-grounding conductor and grounding plug. The plug must be plugged into an outlet that is properly installed and grounded in accordance with all local codes and ordinances.



Never alter the AC cord or plug provided. If it will not fit outlet, have proper outlet installed by a qualified electrician. Improper connection can result in a risk of electric shock.

BATTERY CHARGER CONNECTION PRECAUTIONS

Connect and disconnect the DC output plug (or clips) only when the AC cord is disconnected from the electric outlet. Never allow clips to touch each other.

When hooking up the charger, attach the plug into the twist-lock receptacle on the side of the battery box or connect the clips directly to the battery on units that are not pre-wired with a plug on the side of the battery box.

For unit not equipped with a twist-lock, pre-wired charger plug, follow these additional precautions.

Check polarity of battery posts. POSITIVE (POS, P, +) battery post usually has larger diameter than NEGATIVE (NEG, N, -) battery post. Determine which post of battery is grounded (connected) to the chassis of the machine. Connect the NEGATIVE (black) clip from the battery charger to the machine chassis as far away from the battery as possible. The POSITIVE (red or white) clip from the battery charger to the POSITIVE (POS, P, +) post of the battery. When making each connection, twist or rock clip back and forth several times to make a good

connection and to reduce the risk of a clip slipping off and creating a spark. Do not twist or rock clip on the battery after the second clip connection is made. When disconnecting the charger, disconnect AC cord from the electrical outlet before removing and clips from battery or chassis.

IF THESE INSTRUCTIONS ARE NOT CLEAR OR IF YOU NEED ADDITIONAL INSTRUCTIONS OR IF THERE ARE ANY QUESTIONS, PLEASE CONTACT LiftCOA

OPERATING INSTRUCTIONS

Operating Procedure

Before operating the lift, read and understand this entire section.

⚠ DANGER

The lift may use a power supply of up to 115 Volts AC. This voltage can kill. Do not work with the electrical parts unless you are a qualified electrician!

Locate the lift on a firm, flat surface as shown in Fig. 2. Stationary lifts should be lagged to the floor. The floor lock should be engaged on portable lifts.

⚠ WARNING

If you place the lift on a soft surface, it may tip over, especially when it is loaded or raised. Someone may be hurt, and the lift and load may be damaged. Load the lift correctly.

Be sure that the load weighs no more than the maximum rated capacity for the lift. The maximum rated capacity is shown on the platform skirt.

⚠ WARNING

Do not try to lift a load that exceeds the maximum rated capacity. If you try this, the lift may fail suddenly. Someone may be hurt, and the lift and load may be damaged.

- Place the load in the center of the lift table, as shown in Fig. 3.
- Do not try to load the lift while the lift table is moving.
- If you are lifting pipes or other objects which may be able to roll or move, fasten them down, or chock them. Fig. 4. Be sure all workers are clear of the lift. Remove any material which may fall onto the lift.

⚠ WARNING

Do not use the unit to lift people. A specially equipped lift will include operator protection, and a velocity fuse to keep the lift from dropping suddenly if a hydraulic line is damaged.

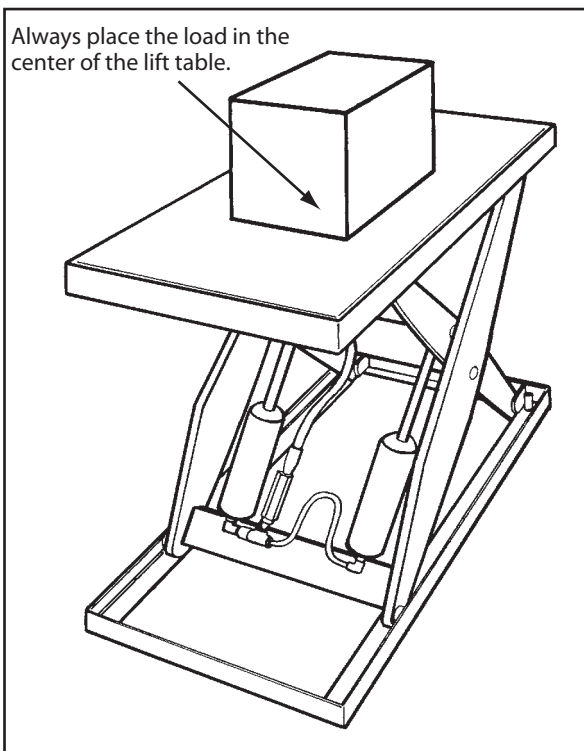

Figure 3 – Center the Load

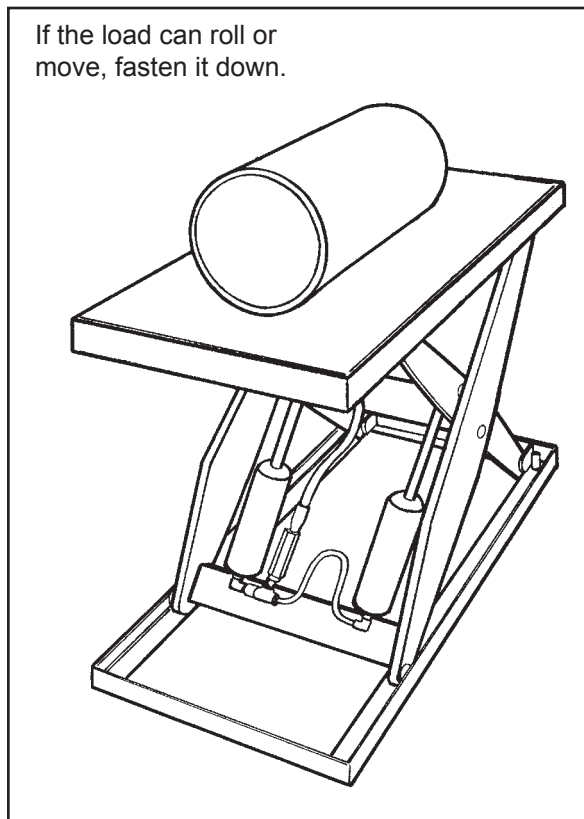

Figure 4 – Secure the Load

⚠WARNING

As the lift table moves up and down, “pinch points” are created as shown in Figures 5 and 6. Stay away from these pinch points! Part of your body or clothing may become caught, and you may be hurt.

Operate the lift. Press and hold the “up” button to raise the lift, and “down” button to lower it. If the lift does not operate right away, turn off the lift and call a qualified maintenance worker.

⚠WARNING

If you hear a squealing noise from the pump, the pressure relief valve is operating. Do not continue to use the lift! The pump will overheat very quickly, and may be permanently damaged. The relief valve is included to protect the machine operators – do not change the relief pressure setting.

Wait until the lift table has stopped. Unload the lift.

NOTICE

The precautionary labels on the lift are there for your safety. If you find that the labels are worn or missing, or have been painted over, ask Maintenance to replace the labels before you use the lift. The labels are shown in Fig. 7

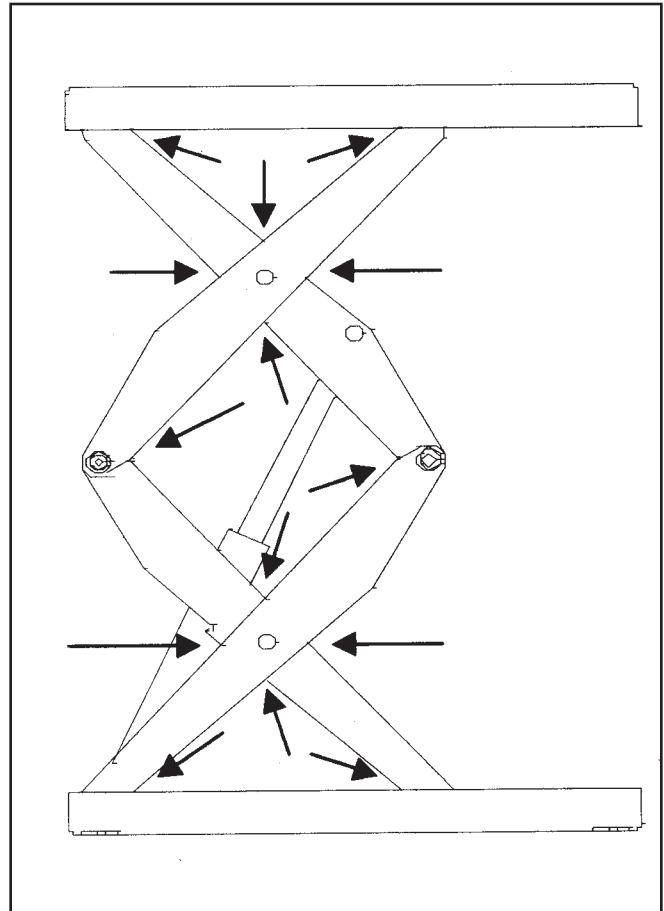

Figure 5 – Pinch Points for CBD

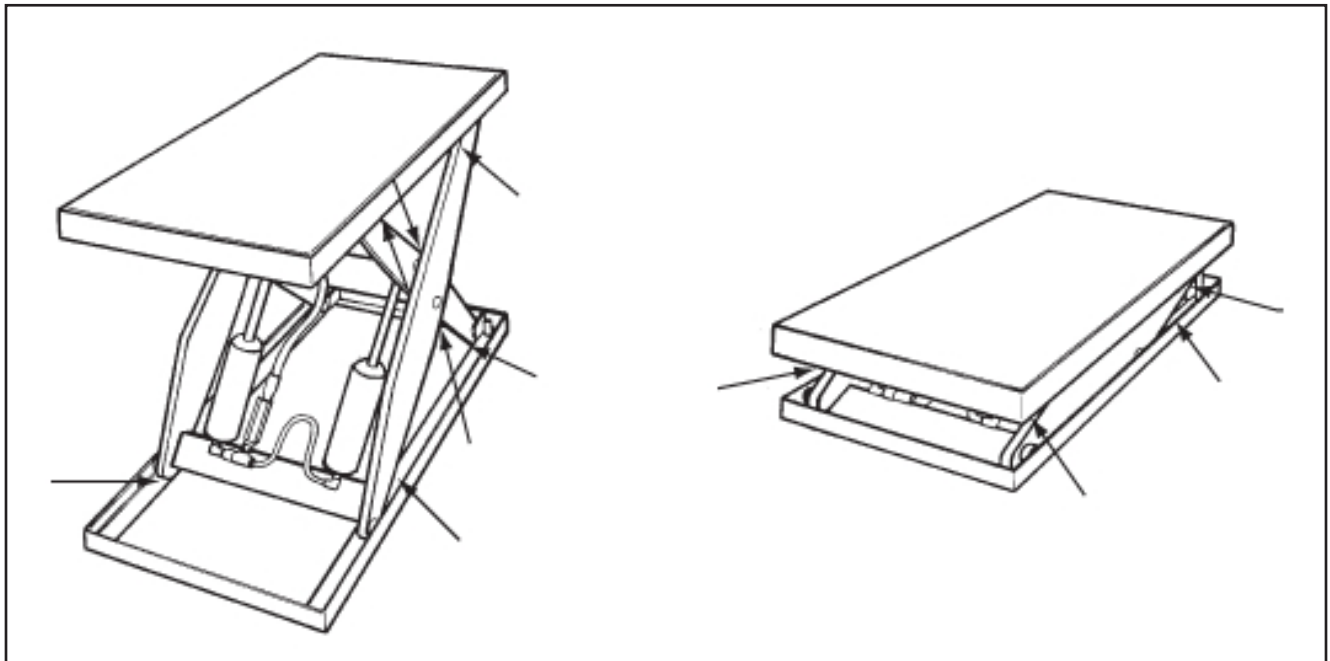

Figure 6 – Pinch Points for CBD

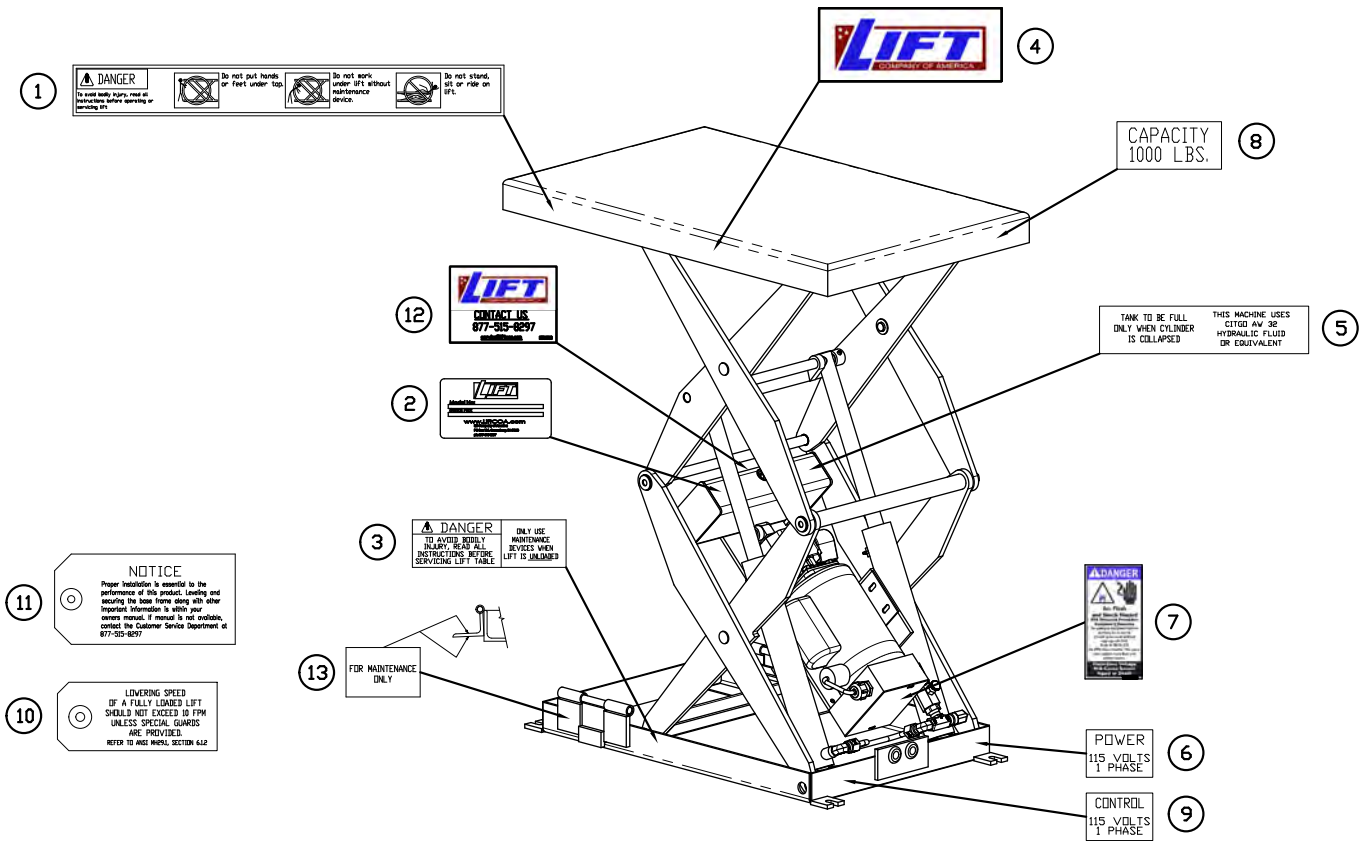

Figure 7 – Labels and Precautionary Markings

Item	Part #	Location
1	2986307	On both sides of the table top as shown (Alt: Both ends of table top)
2	10054118	On tank and underside of table top (Alt: lower strongback)
3	2991182	On leg assembly as close to maintenance device as possible
4	10054093 10054094	On both sides of platform as shown
5	2986997	On hydraulic tank as shown
6	Power Decals: 2987000 (115/1/60) 2987001 (208/3/60) 2987002 (230/3/60) 2987003 (460/3/60) 2991783 (12VDC)	On junction box or base end plate, where wires exit the base as shown

Item	Part #	Location
7	10047672	On junction box cover. (alt: base end plate)
8	Capacity Decals: 2998433 (500#) 2998425 (1000#) 5900159 (other)	Platform Ends
9	2986999	On base end plate as shown
10	2991183	Fasten to flow control
11	10057211	Fasten to flow control
12	10056960	On tank back or front as shown
13	2991927	On both sides of safety chock, as shown.

MAINTENANCE

All servicing should be done by qualified personnel. Qualified personnel should be able to read and understand wiring and hydraulic diagrams. They should be able to troubleshoot live electrical circuits safely and in accordance with accepted practice. **For safety's sake**, if in doubt, please contact your dealer or LiftCOA's Customer Service Department at 877-515-8297. Before servicing the lift, read and understand this entire section and the section entitled "Operating Instructions."

Hazards

There are several hazards you should be aware of as you service the lift:



The lift may use a power supply of up to 575 Volts AC. This voltage can kill. Do not work with the electrical parts unless you are a qualified electrician!



• As the lift moves up and down, "pinch points" are formed as shown in Figure 6. Keep hands, feet, and loose clothing away from these pinch points. If your hand or arm or a part of your clothing is caught, you may be hurt.

• A falling lift can cause severe personal injury. Before working under the lift, raise the lift and insert the maintenance devices, as shown in Figure 1. Do this every time you work under the lift!



• Do not change the setting on the relief valve. If you do change the setting, this may cause a hydraulic part to fail. The lift may drop suddenly. Someone may be hurt, and the lift and the load may be damaged. The hydraulic parts in the lift are designed to handle a certain amount of pressure. The relief valve is set to relieve this pressure before it becomes too great. The relief valve has been included for the protection of all of the workers who use the lift.

• Release of fluids under high pressure can cause personal injury. Before you open any part of the hydraulic system, be sure to release the hydraulic pressure.

• The warning labels on the lift are there for the safety of the operators. See Figure 7. If the labels are worn or missing, or have been painted over, replace them before releasing the lift for operation.

Routine Periodic Maintenance

Every month:

- Visually inspect the leg rollers, center pivot bushings and pins, cylinder clevis pins and bushings, and the leg hinge pins and bushings for signs of wear. Contact LiftCOA for instructions for repair of the center pivot pins and bushings.



If you are going to repair the center pivot pins and bushings, you must support the lift table in a special way. Each set of leg plates, on both sides of the unit, must be clamped together firmly, using large C-clamps. You cannot use the maintenance devices shown in Figure 1 – with the pivot pins removed, they will not support the table top. If you do not support the lift table correctly, the top may drop suddenly when you remove the pivot pins. Please contact LiftCOA for instructions.

Apply oil or WD-40 to the parts listed in the last step.

NOTE: Although the bearings are "lifetime lubricated" their performance may be extended by additional periodic lubrication.

Every six months or 500 hours of operation, whichever comes first:

Raise the lift and insert the maintenance devices, as shown in Figure 1. Check all of the hydraulic fittings and hoses, and repair the connections as necessary. Occasionally the fittings can be worked loose by the vibrations from the power unit.



If a hydraulic fitting becomes loose, or if a hydraulic hose breaks, the hydraulic fluid may escape from the system under pressure. If the lift is raised when this happens, it can drop quickly. Someone may be hurt, or the lift or load may be damaged.

The clear plastic vent line and the cylinder rod(s) should be free of hydraulic fluid. If you find much fluid in either place, the cylinder seals may be leaking. (It is also possible the tank may be overfilled.) See the section on "Repacking LiftCOA Cylinders."

- Check the level and appearance of the hydraulic fluid. Use a dipstick to check the oil level, and add oil as necessary. Change the oil if it has darkened, or feels gritty or sticky.

- Drain and discard the hydraulic fluid. The suction filter is in the tank, at the point where the suction line runs out to the pump. Unscrew the hydraulic filter.
- Blow the filter clean. Reinstall the filter in the tank and reassemble the hydraulic line.
- Refill the tank with new hydraulic fluid.



It is important to use hydraulic fluid with the correct grade and properties. See the hydraulic oil specification in this manual, Table 1.



If you continue to use fluid after it has “worn out,” the moving parts in the system will wear more quickly.

Be sure all of the warning labels are in position and legible. The labels are shown in Figure 7. **The warning labels are intended to protect your workers.** If the labels are missing, or if they have been painted over, replace them.

Maintenance for Units with Air Motors

The vanes in the rotary-type air motor take up their own wear, and will last 5,000 to 15,000 hours of operation. (The actual service life depends on the operating speed, method of oiling, operating pressure, and the precautions taken in maintaining the machine.) The type of shaft seal used will not withstand pressures of more than 100 psi.

An automatic airline lubricator must be installed in the airline just ahead of the air motor. (The filter, regulator, and lubricator are not supplied by LiftCOA.) The lubricator must be adjusted to feed one drop of oil for every 50 to 75 cfm of air going through the motor. This lubrication is necessary to reduce friction on all internal moving parts, and to prevent rust.

The starting torque of the air motor is greater than the running torque. This could vary depending on the position at which the vanes stop in relation to the air intake port. It is advisable to use a pressure regulator or a simple shut-off valve to obtain the desired power, speed and torque, and to conserve air.

CAUTION!

Do not allow the air motor to “run free” at high speed with no load. This can cause buildup of excessive heat and loss of internal clearances, and can damage the motor quickly.

If the motor is sluggish or inefficient, try flushing it with solvent. To flush a motor, disconnect the airline and muffler. Add several teaspoons of solvent directly into the motor. (LiftCOA recommends Gast Flushing Solvent AH255.) Rotate the shafts by hand in both directions for a few minutes. Reconnect the airline and gradually increase the air pressure and flow until there is no trace of the solvent in the exhaust air. Re-lubricate the motor with a squirt of oil in the chamber.

TROUBLESHOOTING CHECKLIST

All servicing should be done by qualified personnel. Qualified personnel should be able to read and understand wiring and hydraulic diagrams. They should be able to troubleshoot live electrical circuits safely and in accordance with accepted practice. **For safety’s sake**, if in doubt, please contact your dealer or LiftCOA at 812-222-2005

Before servicing the lift, **read and understand this entire section and the section entitled “Operating Instructions.”**



Before working underneath the lift, always raise the lift and insert the maintenance devices, as shown in Figure 1. Failure to do so may result in damage to the lift and severe personal injury!

If the lift will not raise:



Do not continue to hold the “up” button for more than 2 or 3 seconds. You may damage the pump.

Check the actual weight of the load. The rated capacity of the lift is shown on the table skirt.



Do not change the relief valve setting. This valve has been included for the protection of workers who install, use, or service the lift. If it is ever necessary to repair or reset the valve, contact LiftCOA for instructions.

If the motor is not running, check the main disconnect switch, the fuse(s) and the wiring to the motor.

Using an external lifting mechanism, such as a crane or fork lift, **raise the lift and insert the maintenance devices as shown in Figure 1.** Be sure to lift the hinged end of the table top.

The hydraulic oil level may be low. When the lift is raised

as far as possible, the oil should be about 3/4 inch above the bottom of the tank. (The exact level varies with different models, especially on models with tanks that tip as the lift elevates.) Use a dipstick to check the oil level.

If your lift has an optional up limit switch, the lift may have reached this upper limit. If the switch is out of adjustment, the lift may not be able to raise completely. Readjust the switch if necessary.

CAUTION

Do not disconnect the up limit switch. Instead, loosen the adjusting screw, and change the position of the arm. If you do disconnect the switch, when the lift platform moves up, it may not stop at the correct point. If the platform rises above the normal stopping point, the frame of the unit may be damaged. People working nearby may be hurt.

The motor voltage may be too low. Check the voltage at the starter when the motor is under load. The supply voltage should be within 10% of the rating.

On a lift with an external power unit, the tank vent may be plugged. You must remove the solid plug from the tank and insert the vented plug. The vent line must be clear.

The suction filter may be clogged. Clean the suction filter as described in the section on "Periodic Maintenance."

A vacuum leak may be allowing air into the suction line, causing cavitation (loss of suction) in the pump. Check all fittings in the suction line, and repair as necessary.

CAUTION

If cavitation is allowed to continue, the pump may be damaged, and may have to be replaced.

For the lift to raise, the down valve must be de-energized and fully closed. Check for a problem with the wiring to the down-valve. Check the solenoid in the valve with a volt meter. The valve must be clean and free to operate. To check this, remove the solenoid and then the valve. Look for contamination which could block the valve action. Clean the valve plunger with kerosene, then blow it clean with compressed air. The expansion nut which holds the solenoid should be finger tight only!

If the pump has been changed, the coupling may not have been installed. See the pump assembly in Fig. 12.

If the lift elevates, but fails to hold a load:

1. Raise the lift and insert the maintenance devices, as shown in Figure 1.

WARNING

Failure to insert the maintenance devices may result in damage to the lift and severe personal injury!

2. The check valve may be leaking. Dirt on the valve seat will prevent the valve from closing fully. The check valve is mounted in the base of the pump housing, as shown in Fig. 12. Remove the check valve cap and inspect the valve for dirt or metal chips which may be preventing it from closing. You may be able to restore the seal by lightly rapping the ball into the seat using a 1/4" diameter rod and a small hammer.

3. The down-valve may be energized. While the lift is holding a load, the down-valve should be de energized and fully closed. Check the solenoid in the valve with a volt meter. The valve must also be clean and free to operate. To check this, remove the solenoid and then the valve. Look for contamination which could block the valve action. Clean the valve plunger with kerosene, then blow clean with compressed air. The expansion nut which holds the solenoid should be finger tight only!

4. The cylinder(s) may be leaking. Look for oil on the cylinder rod(s) and in the vent line. (This may also occur if the oil tank has been over-filled.) If you find much oil in either place, and the tank is not overfilled, the cylinder(s) need to be repacked. See the instructions in this manual on "Repacking LiftCOA Lift Cylinders."

If the lift fails to lower:

1. Insert the maintenance devices, see Figure 1.

WARNING

Failure to insert the maintenance devices may result in damage to the lift and severe personal injury!

2. The down valve may be de-energized. When the lift is lowering, the down valve should be energized and fully open. Check the solenoid in the valve with a volt meter. The valve must also be clean and free to operate. Remove the solenoid, then the down valve. Look for contamination which could block the valve action. Clean the valve plunger with kerosene, then blow it clean with compressed air. The strainer screen over the lower part of the plunger must be clean. See Fig. 12. Before reassembly, depress the plunger manually several times to be sure it moves freely. The expansion nut which holds the solenoid should be finger tight only!

3. Optional Feature: The flow control may need to be adjusted. The flow control must be partially open to allow the oil to return from the cylinder(s). See "Complete Installation" for steps to follow when adjusting an internal flow control.

DANGER

Do not try to adjust the flow control while pressing the "down" button. If you try this, the lift table may drop suddenly, and you may be hurt.

If the steps listed above do not solve the problem, please call the LiftCOA's Customer Service Department at 812-222-2005.

Repacking Cylinders

This section will tell you how to repack a cylinder, shown in Figure 8. This type of cylinder is exclusive to LiftCOA, and repacking kits are only available through LiftCOA. To order a repacking kit, please call the Parts Department at 812-222-2005. When ordering, specify the model number and serial number of the lift, and the cylinder number(s), as listed on the base of the cylinder(s).

Before beginning this procedure, **read and understand this entire section.**



Before working underneath the lift, always raise the lift and insert the maintenance devices, as shown in Figure 1. Failure to do so may result in damage to the lift and severe personal injury!

1. Before you disassemble the old cylinder, be sure you have these items on hand:
 - A repacking kit. Parts may be damaged when you disassemble the cylinder. You should have replacement parts on hand so you can reassemble the lift and use it immediately.
 - A supply of new hydraulic oil. Contaminated oil may damage the new packing.
 - A container to catch the used oil.
 - A clean place to work. Choose a place which will not be damaged if you spill some oil.
2. Raise the lift and insert both the maintenance devices, as shown in Figure 1.
3. Turn off electrical power by unplugging the machine. This will prevent the lift from moving accidentally while you are working on it.
4. Disconnect the cylinder supply line at the pump, and place the end into a container to collect the used oil.
5. Disconnect the vent line at the cylinder(s).
6. At the top end of the cylinder rod, remove the “keeper,” and drive out the clevis pin. Push the rod back into the cylinder to drive the hydraulic fluid out through the hose into the container. You may use air pressure at the vent hole to do this. Disconnect the hydraulic line(s) from the cylinder(s). Lift the cylinder(s) out of the lift. Be careful! The cylinder is heavy!
7. Fig. 8 shows the parts inside a lift cylinder. At the upper end of the cylinder, remove the snap ring. Pull the rod and piston all the way out of the cylinder. This assembly is heavy! Be careful not to drop it as it comes free.
8. Remove the press-fit bushing from the hole at the upper end of the cylinder rod.
9. Look for deformation around the hole at the clevis

end of the cylinder rod. If necessary, clean up the rod diameter with a file to allow the rod bearing to slide off without damage.

10. Remove the plastic rod bearing from the cylinder rod. Observe how the wiper ring sits in the rod bearing. Remove the wiper ring and the O-ring from the rod bearing. Do not try to remove the aluminum piston from the cylinder rod, as this will damage the assembly. Remove the poly U-cup and the fiber wear ring from the piston.

11. Check the vent plug, and clean it if it appears dirty.



While reassembling, it is very important to keep all of the parts free of dirt, dust, metal chips, water, and other contamination. Most of the problems with hydraulic systems are caused by contamination in the oil.

12. Clean the piston surfaces, and install a new fiber wear ring. Install a new poly U-cup seal, with the open part of the seal facing down.

13. Clean all of the surfaces on the rod bearing. Install a new O-ring and wiper. Replace the rod bearing assembly on the rod



Be careful not to install the wiper backwards. The lip on the wiper should point upwards, as shown in the detail in Figure 8.

14. Clean the bore of the cylinder tube thoroughly. Inspect the bore of the tube for scratches that run up and down, along the length of the cylinder. If you do see any scratches, hone the inner surface of the cylinder. Be sure to clean the tube thoroughly after you do this.

15. Lubricate the seal and piston with clean grease or oil. Carefully insert the piston and rod back into the cylinder. Be very careful not to pinch or tear the poly U-cup as the piston passes the shoulder inside the cylinder. It is helpful to tip the rod assembly and twist it as you slide it into the cylinder. Once the piston is inside the cylinder, it should slide easily.



If the poly U-cup is pinched or torn during reassembly, the piston may not maintain pressure as designed.

16. Slide the rod bearing into the cylinder. Install a new snap ring to hold the rod bearing in place. Replace the bushing or install a new one in the top of the cylinder rod.

17. Install the cylinder in the lift. Replace the clevis pin and “keeper.” Reconnect all of the hydraulic lines and the vent line.

18. At the start of the packing process, you drained the cylinder(s) into a container. Replace this used oil with

an equal amount of fresh oil. Be sure to reinstall the vent plug when you're done.

19. Turn on the electrical power and press the "up" button. The pump will self-prime. After a few seconds, the cylinder should lift the table off the blocks. Remove the maintenance devices. Cycle the lift up and down a few times to remove air pockets. Check for leaks.

20. Raise the lift and check the oil level with a dipstick. The oil should be about 3/4 inch above the bottom of the tank.

21. If you have spilled any oil, clean it up.



Spilled hydraulic oil is slippery, and may present a fire hazard. Always clean up any spilled oil.

Replacing Leg Rollers

Please contact Customer Service at LiftCOA for instructions for your model and application at 812-222-2005.

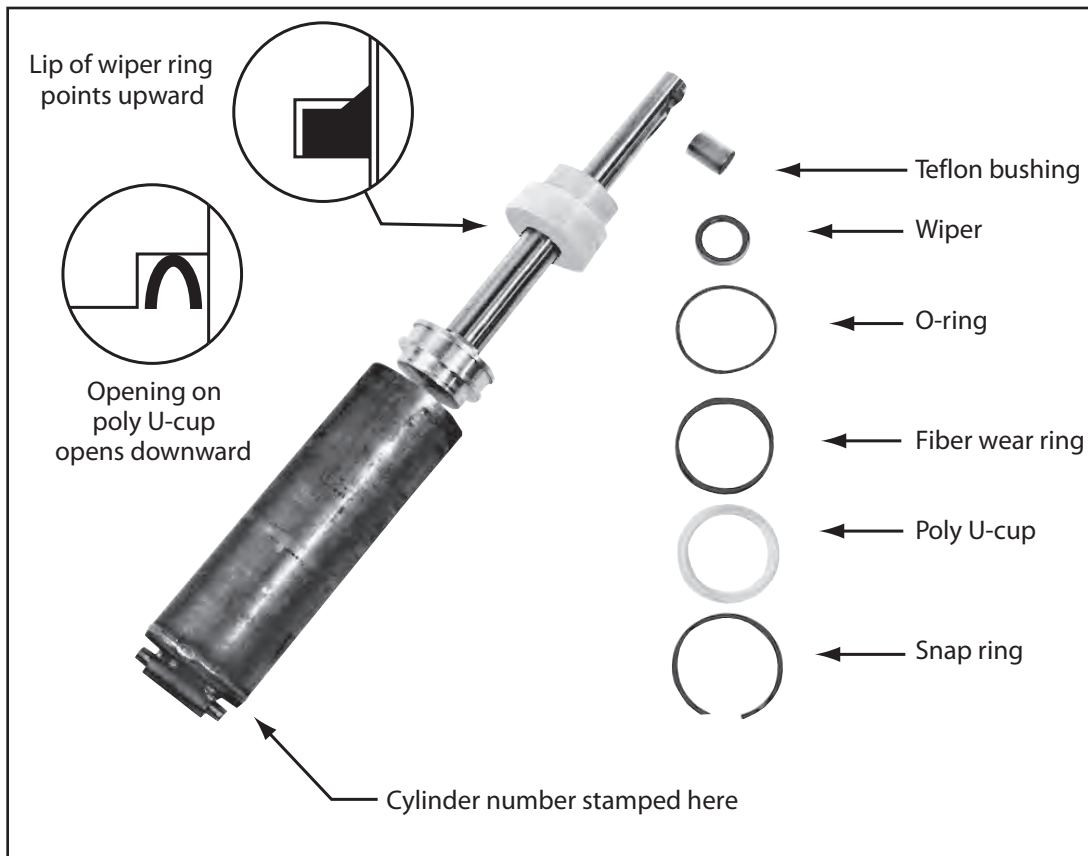

Figure 8 – H-Style Cylinder

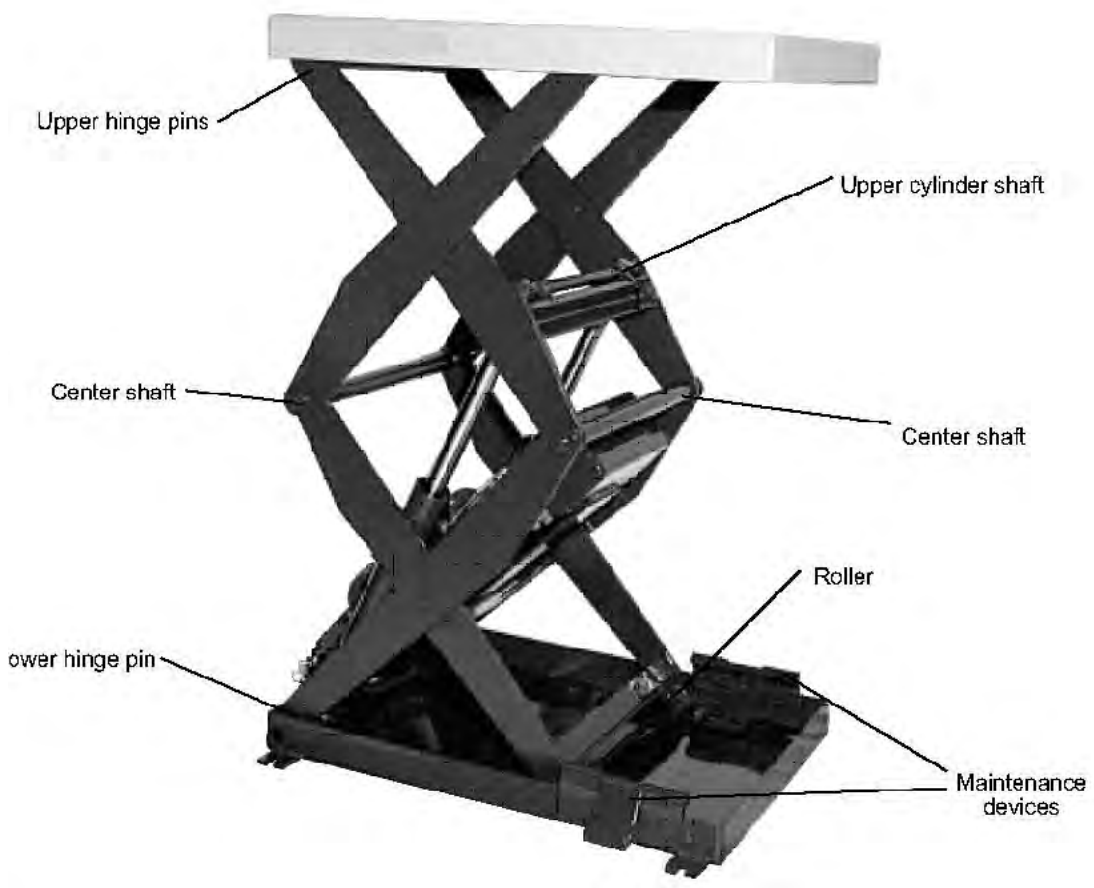
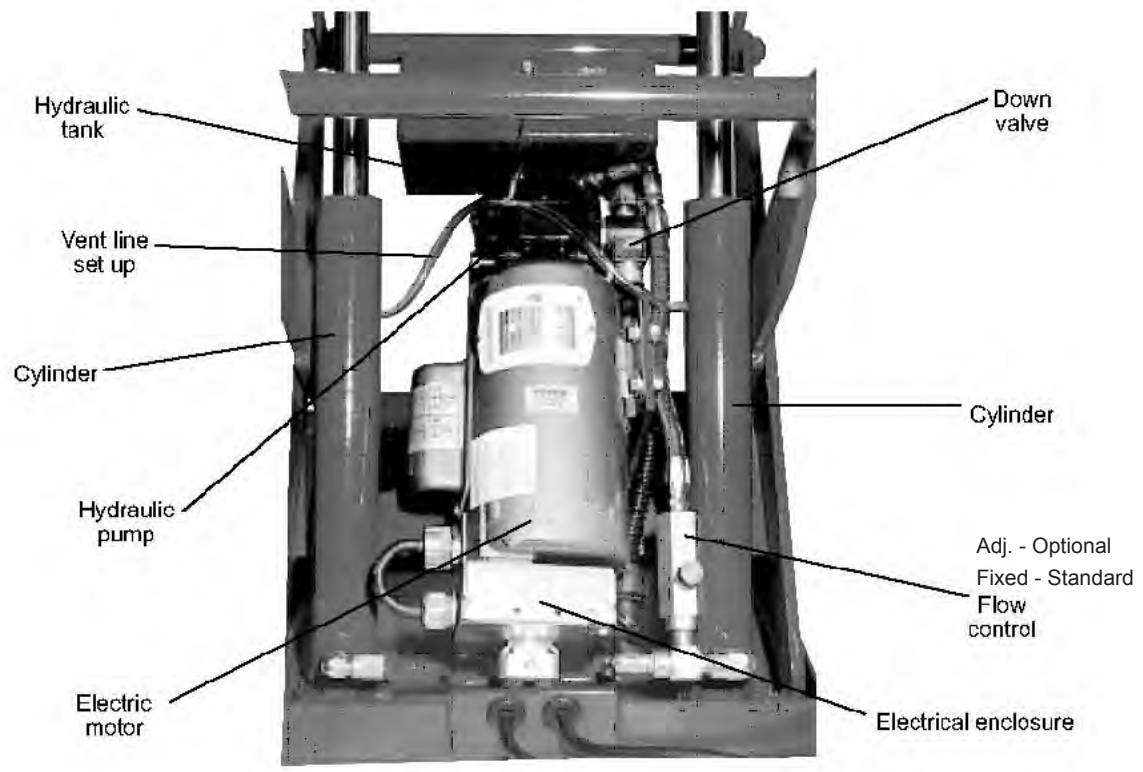

Figure 9 – Parts Identification, CBD Compact

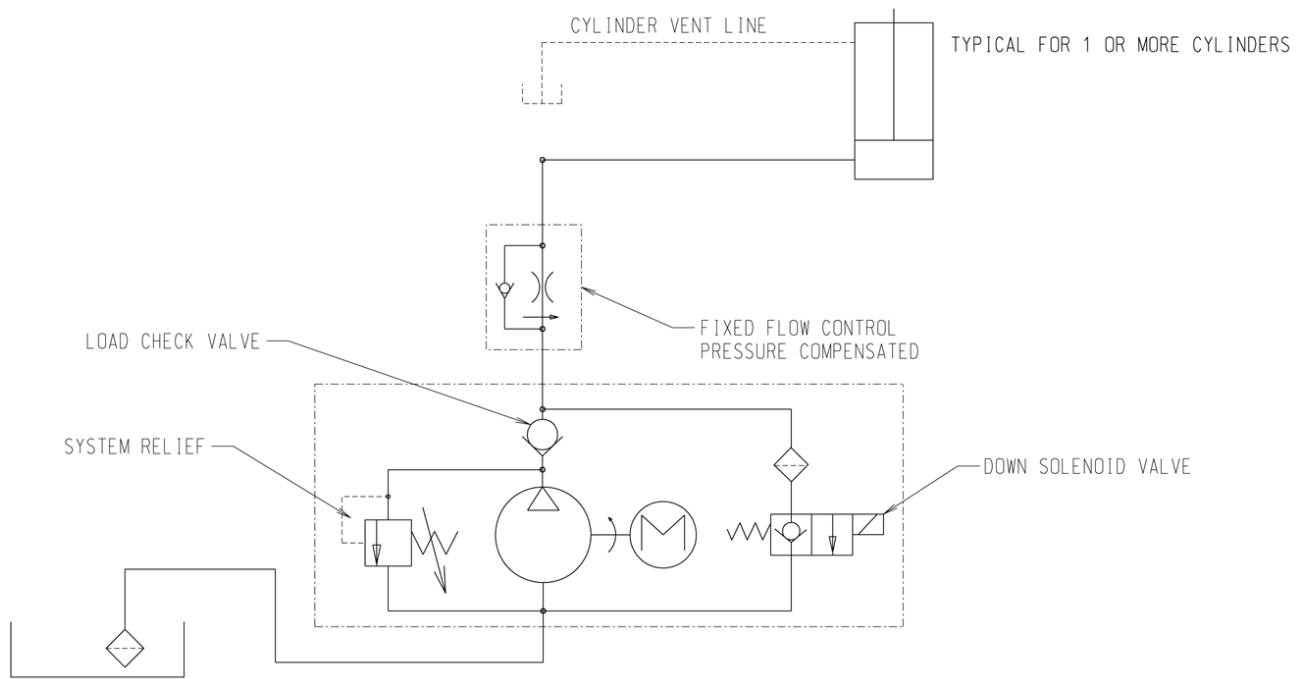

Figure 10 – Hydraulic Diagram - Unit Powered by Electric Motor

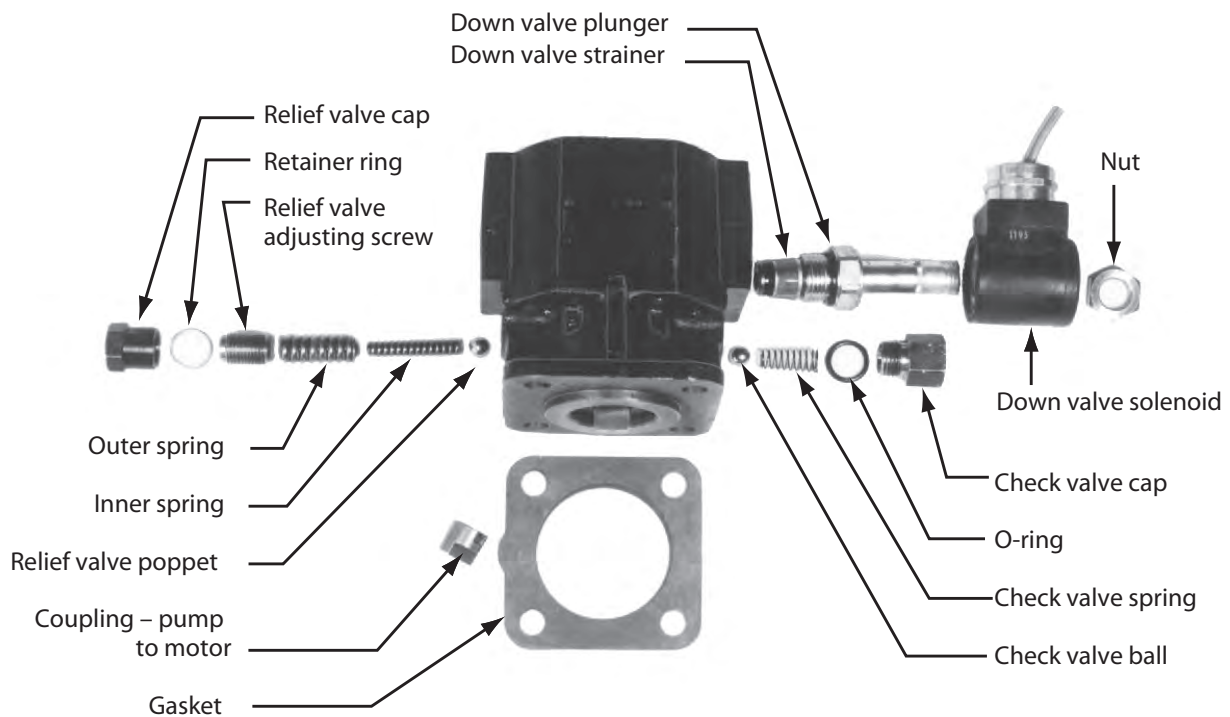

Figure 11 – Hydraulic Pump and Down Valve

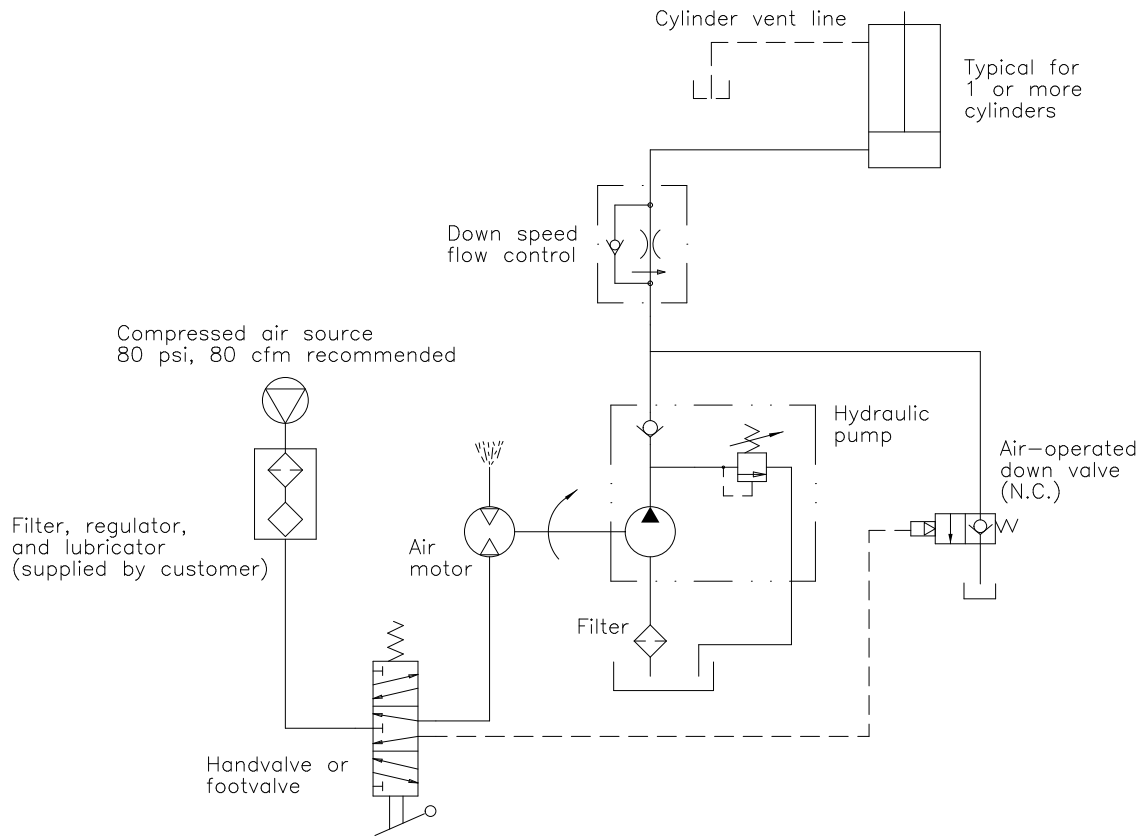

Figure 12 – Hydraulic Diagram - Unit Powered by Air Motor

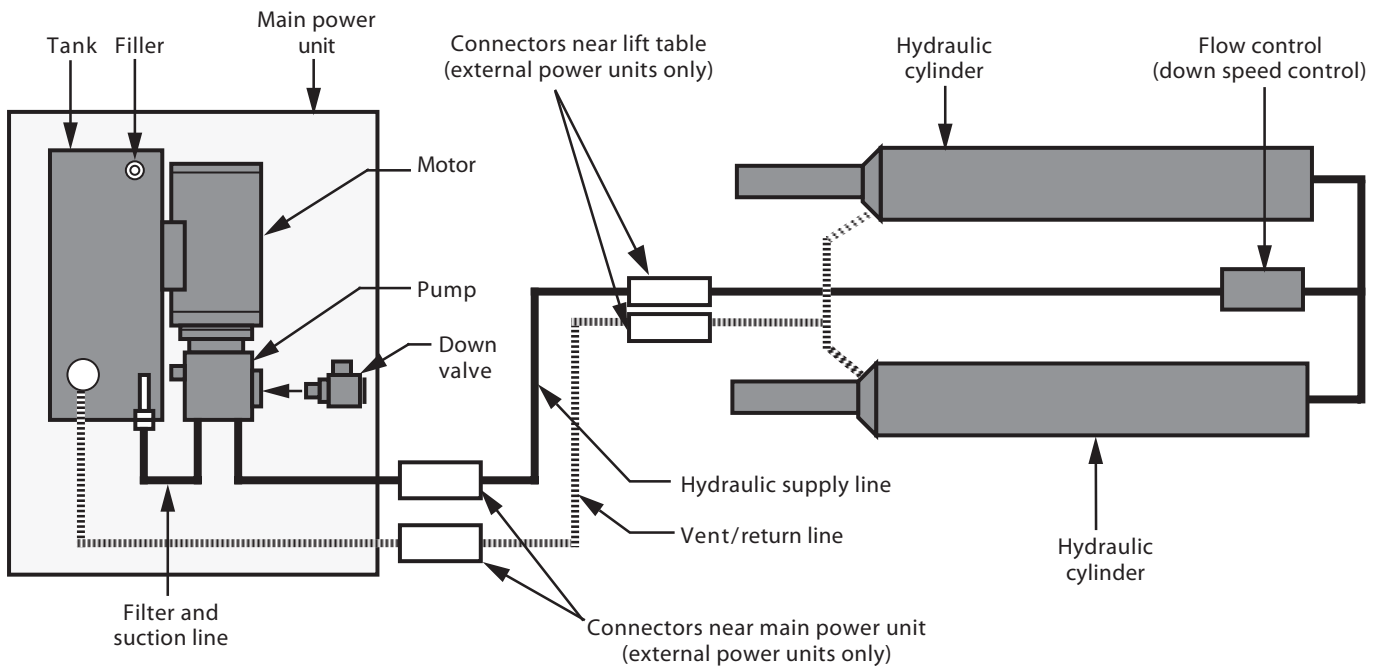
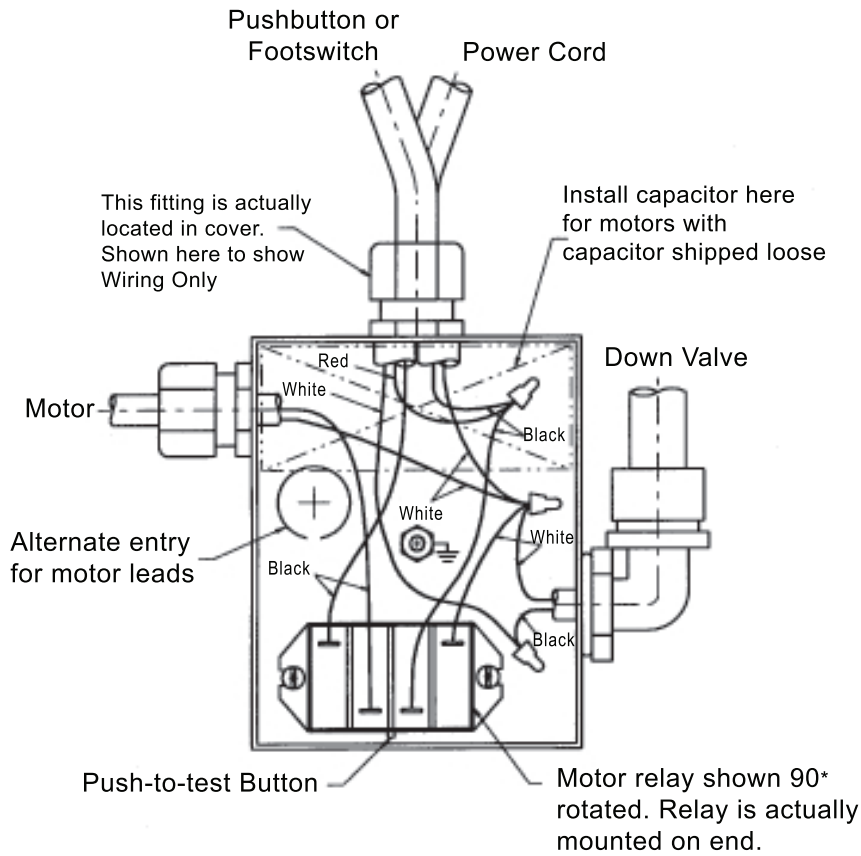

Figure 13 – Hydraulic Connections



NOTE:
Ground wires from motor, power cord, and pushbutton or footswitch are not shown for clarity. Attach all grounds to the enclosure grounding lug.

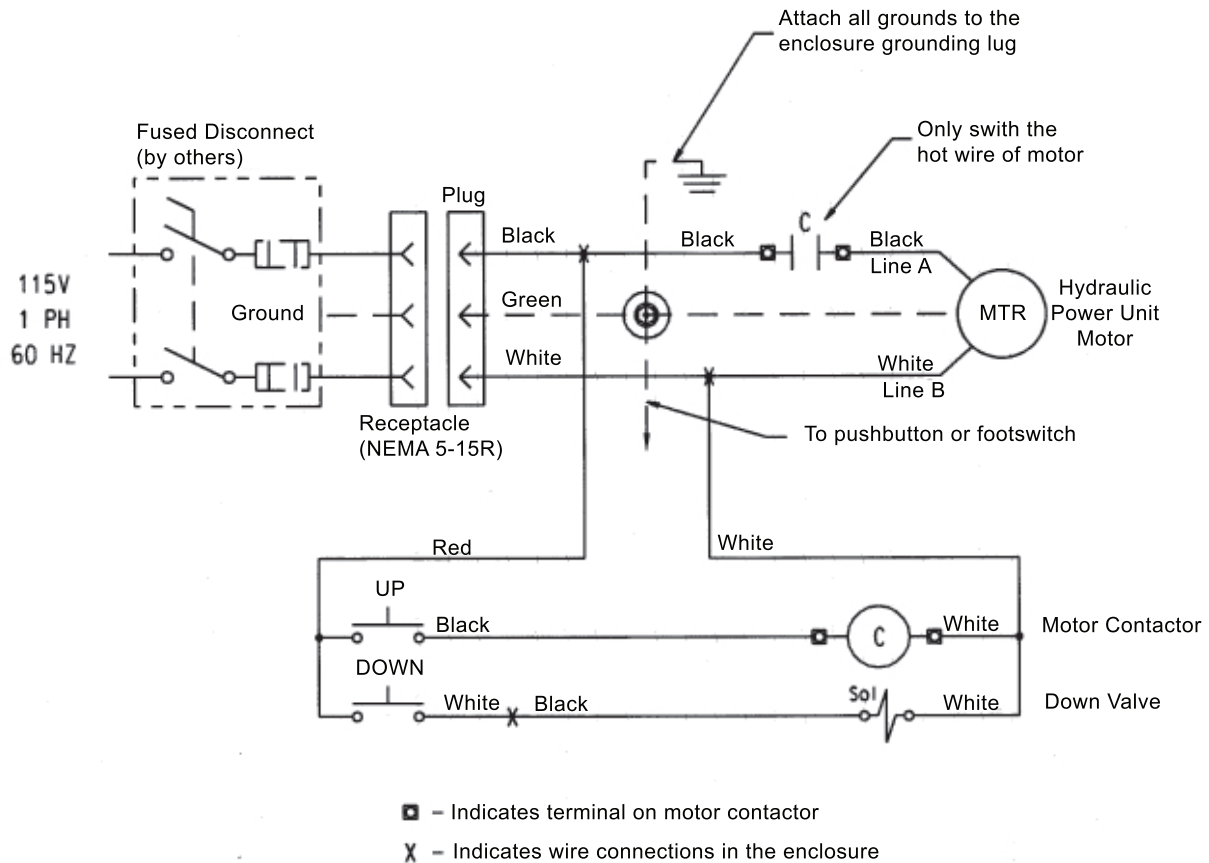

Figure 14 – Electrical Connections, Diag. For 1-Phase AC

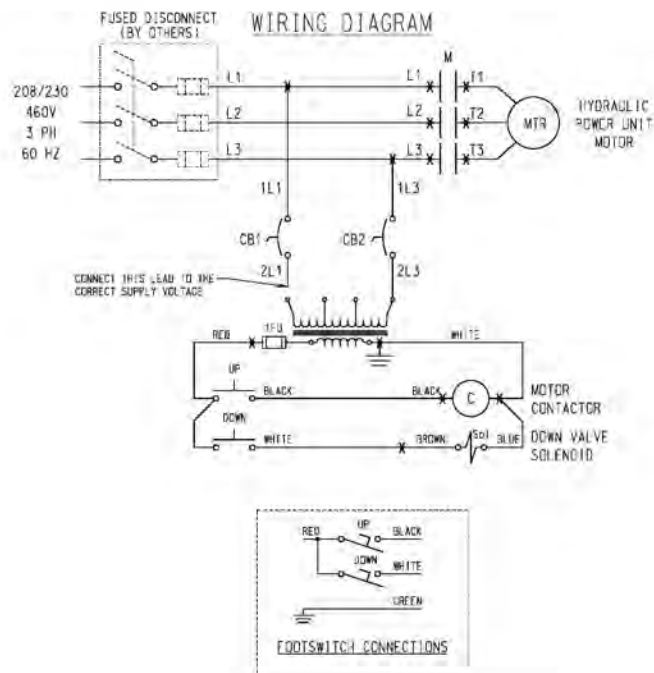
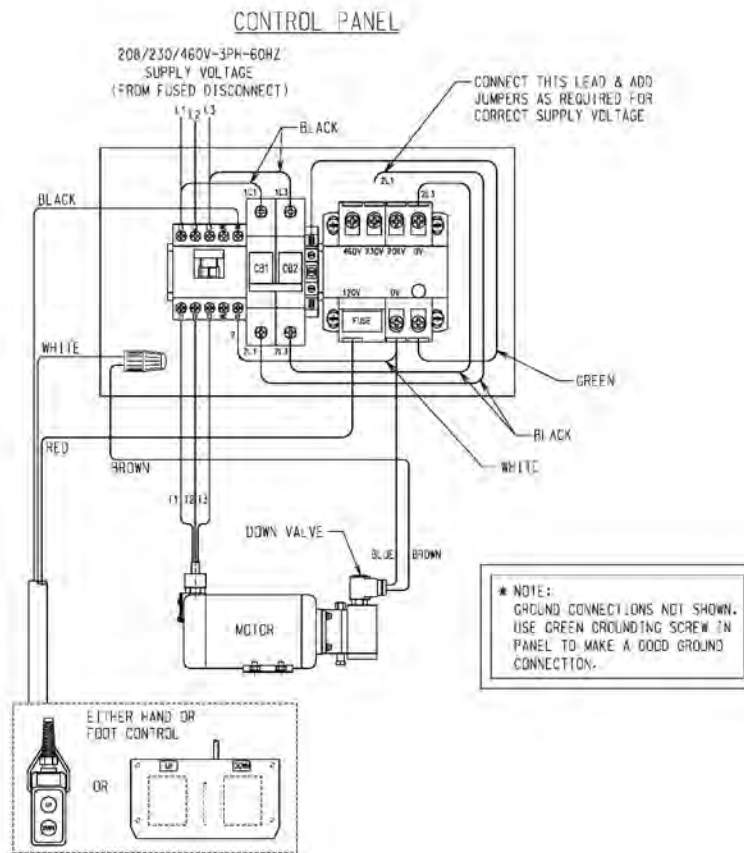

Figure 15 – Electrical Connections, Diag. For 3-Phase AC

Ordering Replacement Parts

LiftCOA has carefully chosen the components in your unit to be the best available for the purpose. Replacement parts should be identical to the original equipment. LiftCOA will not be responsible for equipment failures resulting from the use of incorrect replacement parts or from unauthorized modifications to the unit.

LiftCOA can supply all replacement parts for your lift. With your order, please include the model number and the serial number of the unit. You can find these numbers on the name plate. This plate is located within the scissors mechanism.

To order replacement parts, please call the LiftCOA Parts Department. Parts are shipped subject to the following terms:

- FOB factory
- Returns only with the approval of our parts department.
- Credit cards preferred (except parts covered by warranty).
- Freight collect for truck (except parts covered by warranty).
- Freight – prepaid and invoice for small parcel shipments (except parts covered by warranty).

Parts replaced under warranty are on a “charge-credit” basis. We will invoice you when we ship the replacement part, then credit you when you return the worn or damaged part.

Table 1 – Hydraulic Oil Specifications

If the lift will be used at normal ambient temperatures, LiftCOA supplies the unit with Conoco AW 32 oil. This may be replaced by any other good quality oil with 150 SSU at 100° F and rust and oxidation inhibitors and anti-wear properties.

If the lift will be used at ambient temperatures below 0°F, use aircraft hydraulic oil. Use Type 15 aircraft hydraulic oil.

The following are equivalent to CONOCO 32:

TYPE	MANUFACTURER
DTE 24	EXXON/MOBIL
NUTO H32	EXXON/MOBIL
AMOCO AW32	CHEVRON (AMOCO CO.)
AW32	CITGO



It is very important to keep the hydraulic oil free of dirt, dust, metal chips, water, and other contamination. Most of the problems with hydraulic systems are caused by contamination in the oil.

RETURN MATERIALS AUTHORIZATION (RMA) PROCEDURES

Although LiftCOA is not legally obligated to issue a credit for any merchandise, the RETURN MATERIALS AUTHORIZATION (RMA) PROCEDURE is provided as a courtesy to our customers in the event they do not receive what they wanted.

If a customer wishes to return a LiftCOA product, the first step in the process is to request an RMA number from LiftCOA's Customer Service Department. This request must be made on or before the thirtieth (30th) calendar day following the date of LiftCOA's invoice for the merchandise being returned.

The RMA number must appear on the outside of any packaging material for a return to be accepted and processed by LiftCOA. Customers shipping returns back to LiftCOA from the Continental US, Canada and Mexico have fourteen (14) days from the effective date of the RMA to have the merchandise arrive freight prepaid at LiftCOA. Returns from locations other than the Continental US, Canada and Mexico must be shipped within the fourteen (14) day period to arrive Free On Board (FOB) at LiftCOA as soon as practical. If a customer believes LiftCOA's merchandise is defective, freight will be reimbursed to the original "Bill To" on the invoice if LiftCOA finds that the merchandise is defective.

Please remember that merchandise with RMA's coming back to LiftCOA from the Continental US, Canada and Mexico will not be accepted by LiftCOA if the returned goods do not arrive freight prepaid at LiftCOA within the fourteen (14) day effective period.

All credits issued are less restocking fees as applicable, plus any assessed outbound/inbound in-transit damages.

Return addresses: please refer to your RMA for the address to which your product should be returned.

LiftCOA
Tel: 812-222-2005
Fax: 812-222-2013

LiftCOA Limited Warranty Policy

LiftCOA warrants all of its products against defects in the welded structural frame and, if applicable, scissor legs from faulty material and workmanship for a period of five (5) years from the date of invoice.

All batteries are covered under a separate limited warranty from the battery manufacturer for a period of one year from the date of invoice.

All other components have a limited warranty against defects in faulty material and workmanship for a two (2) year period from the date of invoice date of invoice and 30 day limited warranty on labor. Please note that prior authorization from LiftCOA is required on all warranty work.

There are no implied warranties of any kind, more specifically, there are no warranties of merchantability or fitness for any particular purpose. LiftCOA's sole warranty shall be as set forth in this limited warranty.

LiftCOA will elect to repair or replace a defective component without charge, if any components should become defective within the limited warranty period. Proof of purchase is required for warranty. The charge for shipping the defective component is the responsibility of the buyer and must be accompanied with an RMA number. The shipping charge to return the component to the buyer is the responsibility of LiftCOA.

This limited warranty does not cover labor expense for removal or reinstallation of components after thirty days. This limited warranty shall not cover, among other things: damages resulting from foreign matter or water, failure to provide reasonable and necessary maintenance, and if applicable, use of product while charger is plugged into an AC outlet, or failure to follow operating instructions. The limited warranty is not valid for damage resulting from negligence, accident, unreasonable use, abuse or misuse, exceeding data plate capacities or altering the product without LiftCOA authorization.

LiftCOA expressly disclaims and excludes any liability for consequential, incidental, indirect or punitive damages or financial loss to people or property resulting from any breach of warranty or the operation or failure of this product.

LiftCOA makes no representation that this product complies with local, state, or federal safety/product standards codes. Should this product fail to comply in any way with those codes, it shall not be considered a defect of materials or workmanship. LiftCOA shall not be held liable for any damages resulting from noncompliance. It is the dealer's responsibility to exercise this limited warranty. This limited warranty is provided to the original purchaser (defined as the original end user) and is nontransferable. This constitutes the complete and final agreement involving LiftCOA and limited warranty obligations for products.